

CATALOGUE OF PHOTOVOLTAIC SYSTEMS

| 2024

K-500
KONSTRUKCJE FOTOWOLTAIKA

K500 is a Polish brand that is one of the leaders in production of ready-made assembly solutions for systems photovoltaics. The company provides the highest quality products quality that guarantees stable operation of each power plant photovoltaic, regardless of its size.

Own design office and many years of experience in the photovoltaic industry, the company's founders made all the structures K500 are designed with high performance in mind, durability and safety. Before assembly each the design is carefully checked and tested to ensure optimal results.

Each of our structures can be expanded any number of modules.

Steel structural elements are covered with Magnelis® coating, thanks to which the resistance to weather conditions is significantly higher better than with a standard zinc coating.

By choosing K500, you can be sure that you are benefiting from the solutions top shelf. K500 offers:

- 1. free-standing ground structures driven into the ground or attached to a concrete base,**
- 2. Carport type structures,**
- 3. roof structures dedicated to pitched and flat roofs,**
- 4. structural and connecting elements necessary for construction photovoltaic structure.**

Ground structures

- page 6 - K502 construction
- page 8 - Construction K502 level
- page 10 - K503 design
- page 12 - K503 Bifacial construction
- page 14 - K501 construction
- page 16 - K504/K505/K506 design

Concrete structures

- page 18 - Construction K502/503 Concrete

Carports

- page 20 - Carport standard
- page 22 - Tight carport
- page 24 - Carport X1

Roof structures

- page 26 - K8000 design
- page 28 - K9000 design

*Basic advantages of the **Magnelis®** coating*

- * **Outstanding corrosion resistance:
three times better than galvanized steel
(based on research results)***
- * **Self-regeneration effect
provides excellent edge protection***
- * **The best and most cost-effective
an alternative to hot-dip galvanized steel***
- * **Wide range of available species and dimensions***
- * **Ease of processing***
- * **Eco-friendly***

Magnelis®

What is this ?

Magnelis® is a unique metallic coating, which is a breakthrough in corrosion protection. It is the best material with numerous applications.

The unique chemical composition of the Magnelis® coating provides a previously unseen level of protection cutting surfaces and edges even to the extreme hostile environments.

Magnelis® coating is applied in a typical line for continuous hot dip coating, but bath contains 3.5% aluminum and 3% magnesium.

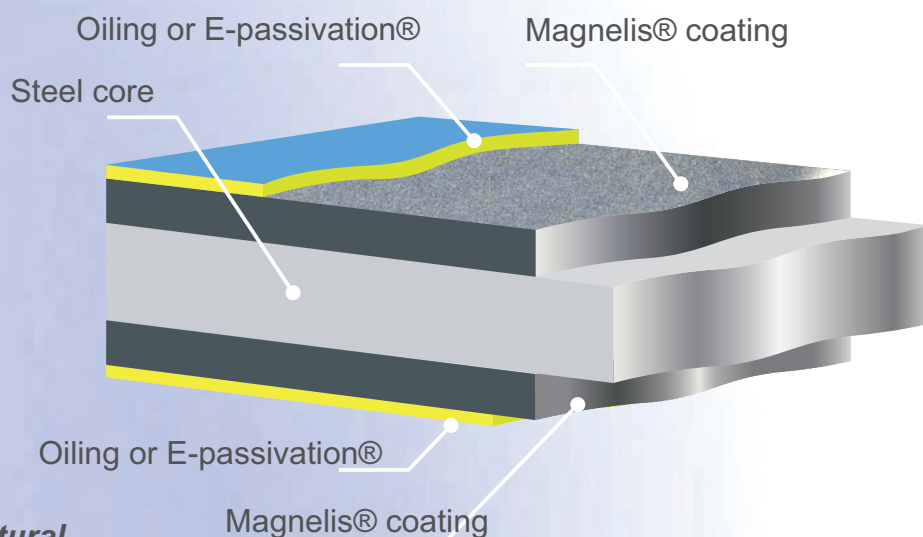
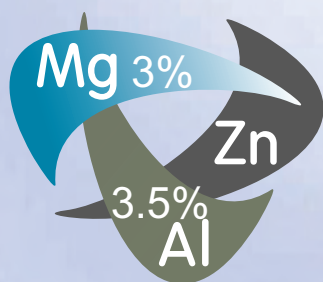

*The Magnelis® coating has a natural dark gray color.
The protected material is environmentally friendly
environmental protection with E-passivation® and, on request, oiled.*

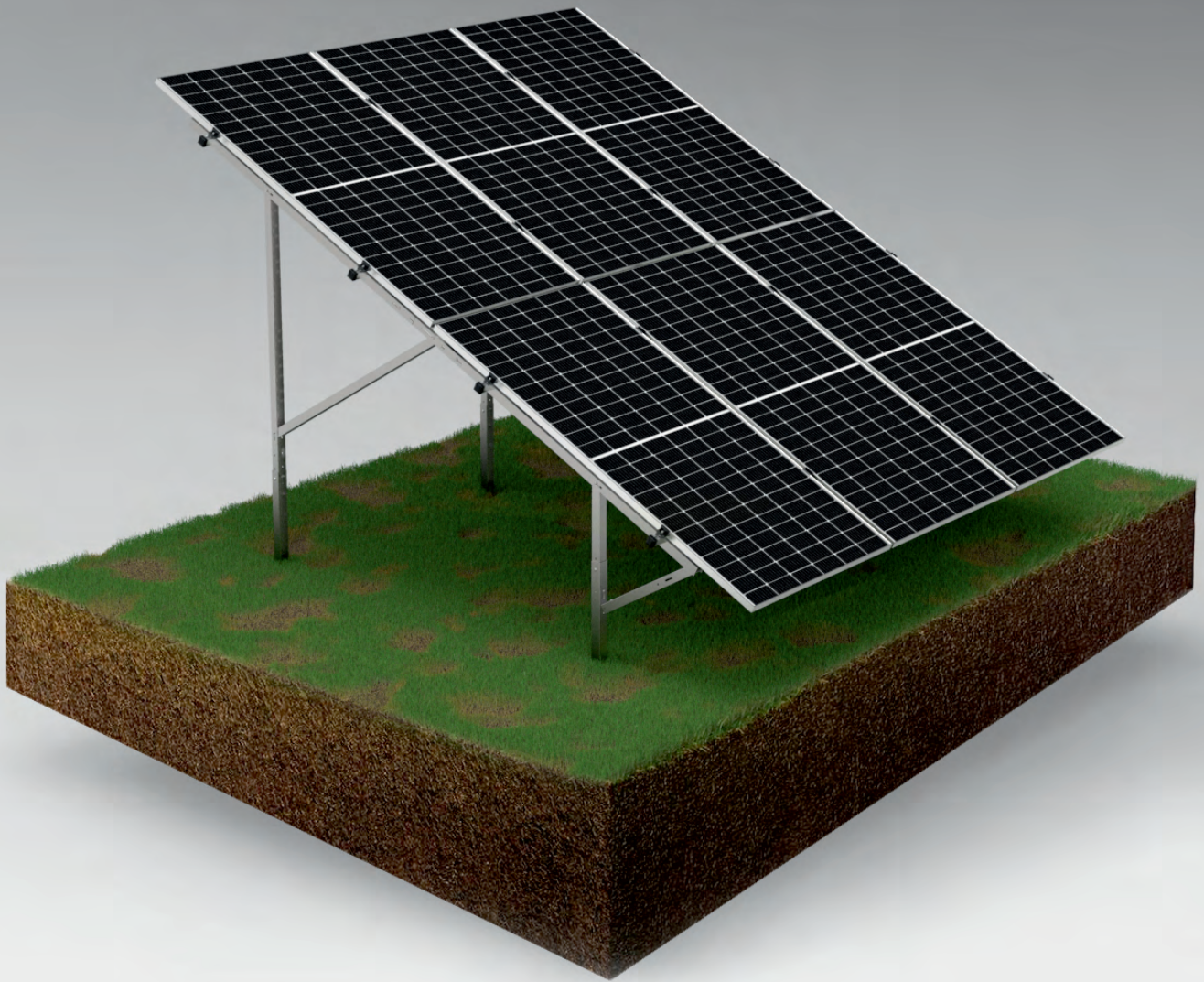

K502

- maximum length
module: 1750mm
- angle of inclination: 30°
- maximum number of modules: 20

K502 Max

- maximum length
module: 2020mm
- angle of inclination: 30°
- maximum number of modules: 20

K502 XL

- maximum length
module: 2200mm
- angle of inclination: 27°
- maximum number of modules: 20

K502/K502MAX/K502XL
are vertical structures
system of 2 modules.
The perfect solution for your backyard
photovoltaic power plant.

Advantages:

- light yet solid construction
- possibility of driving in poles thanks to the K500 matrix
- Magnelis coating guarantees long-term protection against corrosion
- modularity = expandability
- C-type profiles enabling laying/hiding cables
- inclination of 27°/30° relative to the ground.



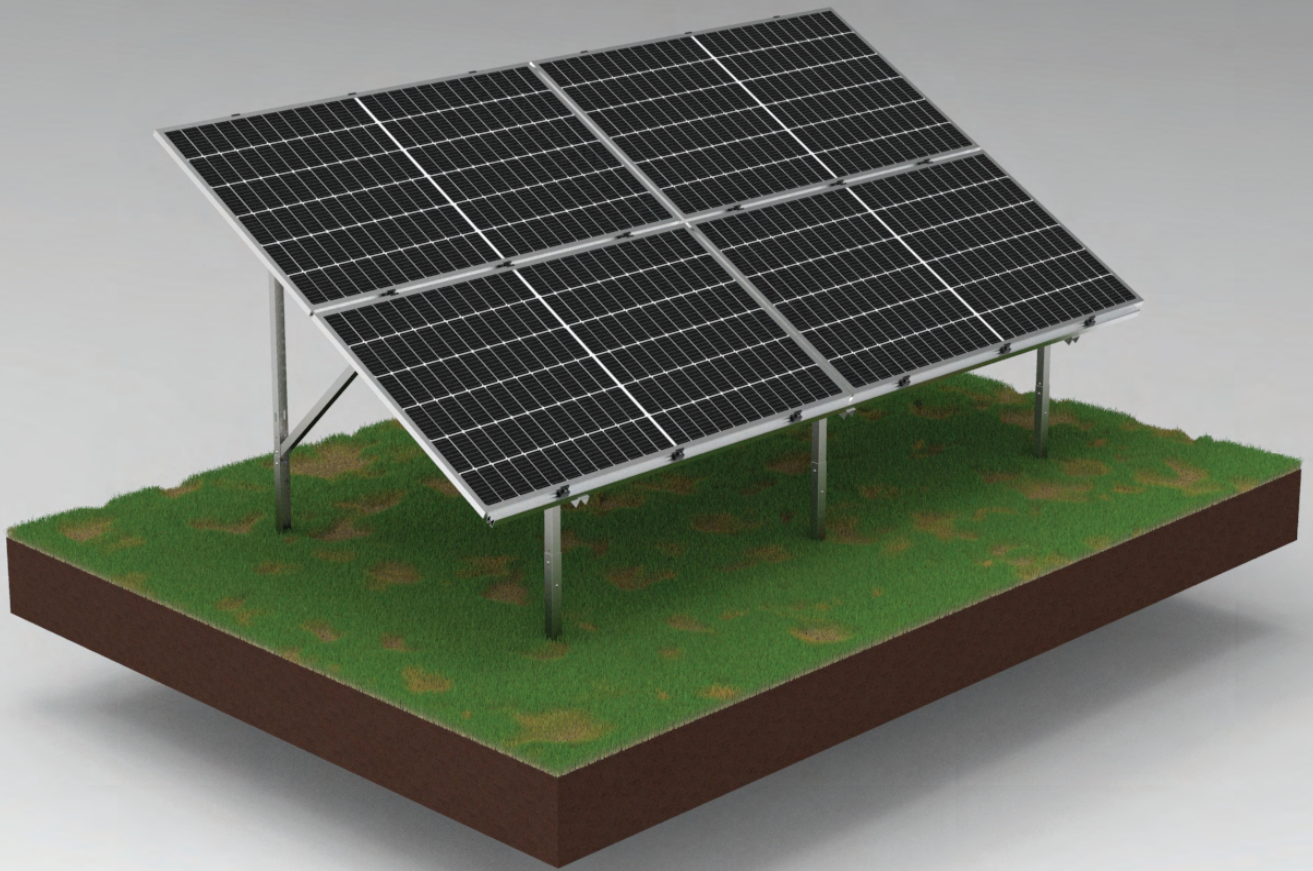

K502 level

- maximum length
module: 2385mm
- maximum width
module: 1310mm
- angle of inclination: 30°
- maximum length of the structure
measured by modules: 14.00 m.

**K502 level - the perfect solution
for large modules
with dimensions up to 2385 x 1310 mm.**

**We met the needs
installers and designed the matrix
output with SDS-HEX quick connector.
The construction of the structure became possible
using an impact hammer,
no need to rent
large pile driver.
Additionally, we made in the matrix
a notch enabling the insertion of poles
with larger cross-sections
e.g. for carport structures.**



SDS HEX matrix



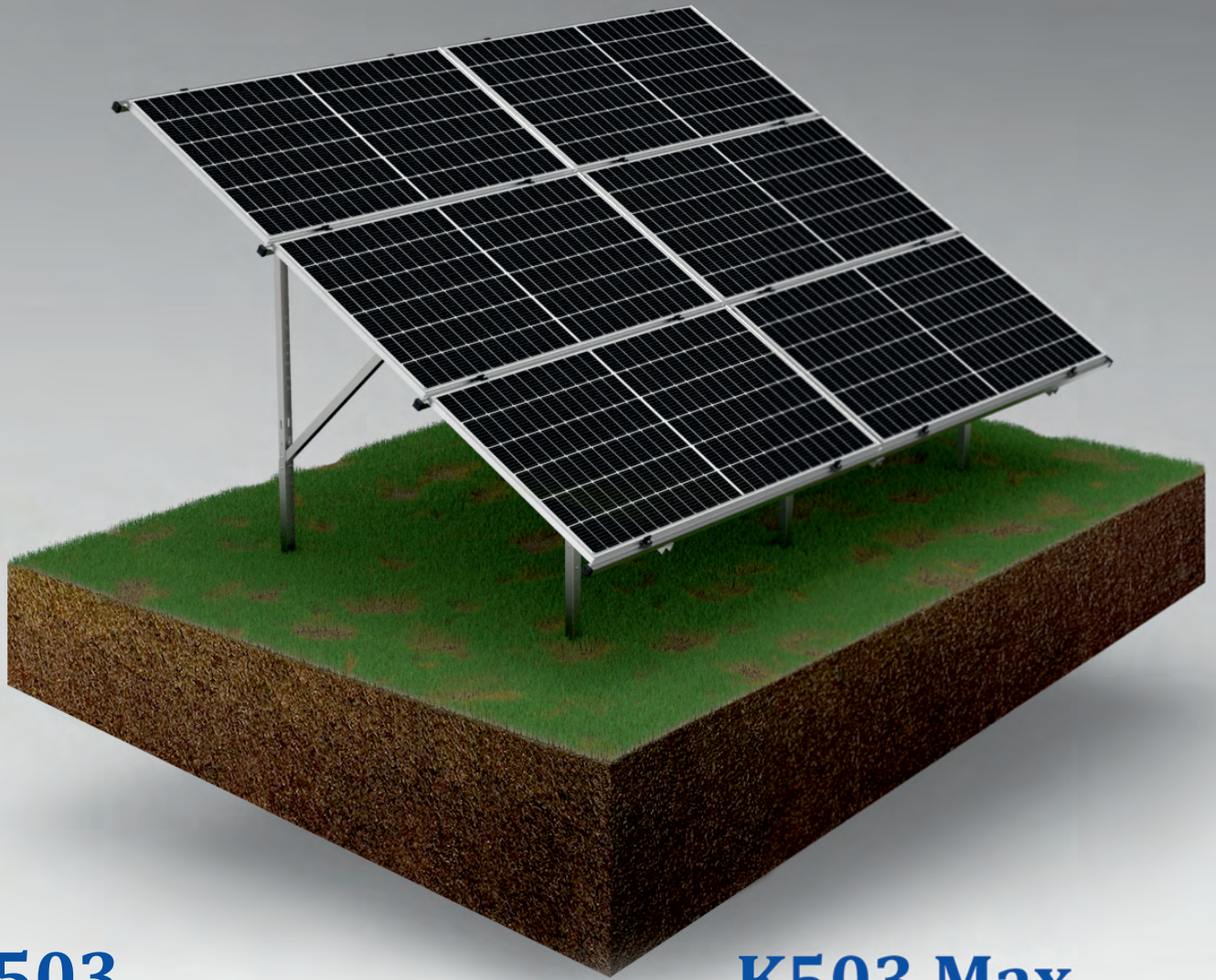

K503

- maximum length module: 1750mm
- maximum width 1052mm module
- angle of inclination: 30°
- maximum number of modules: 21

K503 Max

- maximum length module: 2300mm
- maximum width 1052mm module
- angle of inclination: 30°
- maximum number of modules: 21

K503 XL

- maximum length module: 2300mm
- width from: 1053mm up to: 1152mm
- angle of inclination: 30°
- maximum number of modules: 21

K503 - a structure with a horizontal 3-module panel arrangement. Dedicated to home installations as an alternative for a vertical 2-module system. Simplicity of assembly, connection of steel elements in the Magnelis® coating + rails assembly made of aluminum ensures many years of use durability of the structure in use. Column cross-sections as well they allow the use of our matrix, which greatly facilitates installation.

As K500, we are open to opinions and suggestions regarding facilitating installation work when erecting structures photovoltaics. Another example of this is universal mounting rail for hanging inverters necessary for PV. The rail is equipped with a number of holes for hanging inverter and attaching it to all our types construction.

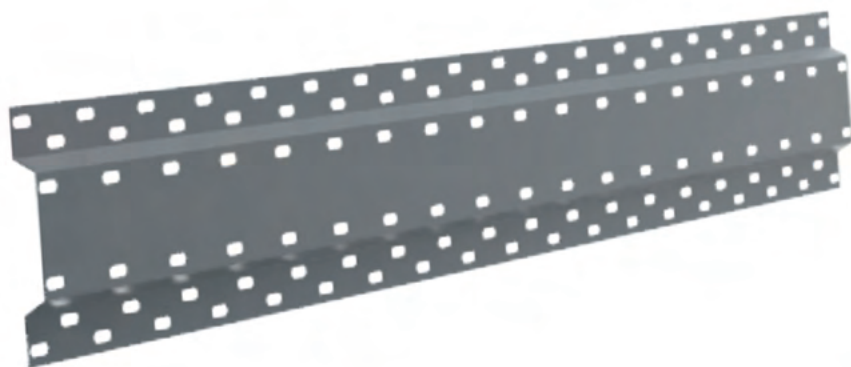

Mounting rail L=2000mm





K503 bifacial

- maximum length
module: 2300mm
- maximum width
module: 1152mm
- angle of inclination: 30°
- maximum number of modules: 21



**K503 bifacial - construction
3 modules stacked
horizontally dedicated to
double-sided modules.
Leg spacing and arrangement
remaining elements
components of the structure
makes panels from
the inner parts are not
not covered in any way,
and also the module distance
from the ground equal to
approximately 1000 mm,
what makes the sun's rays
after bouncing off the ground, they hit
in panels with the largest
possible intensity.**

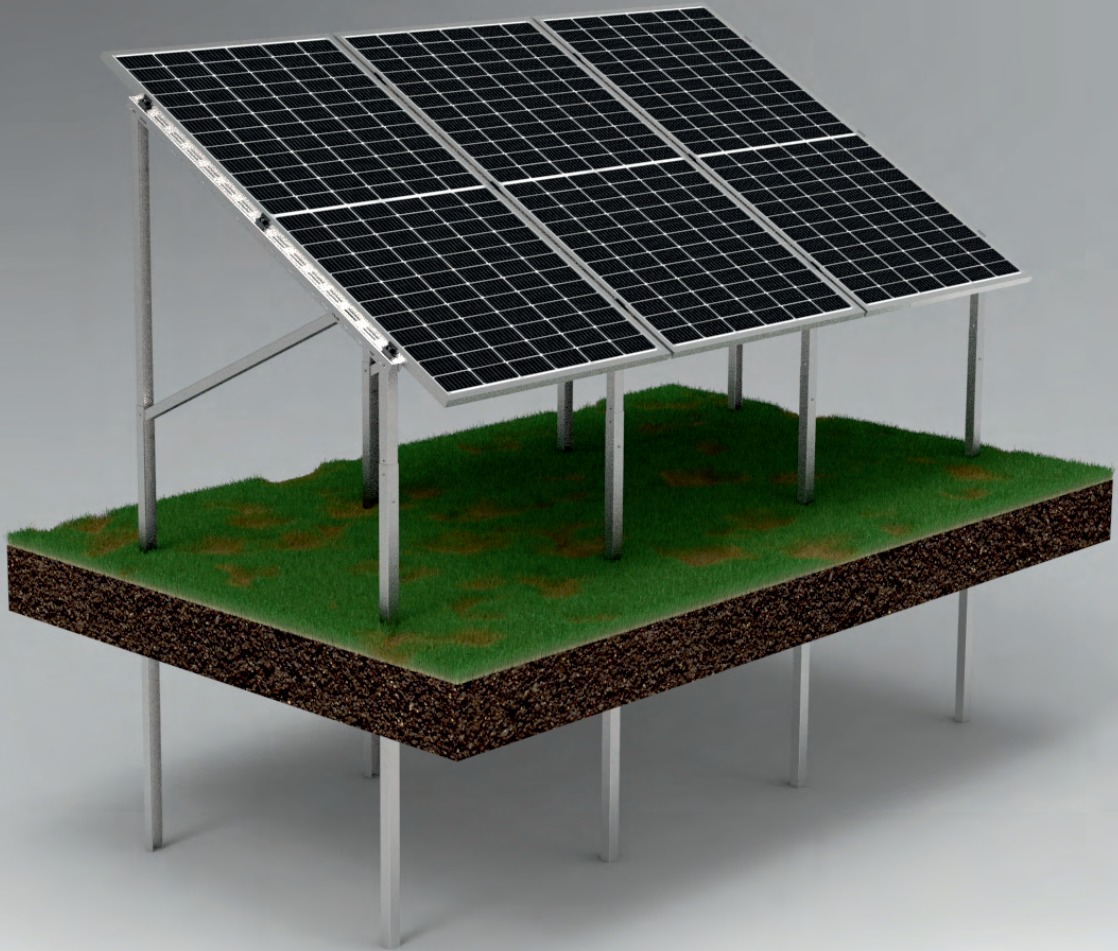

K501

- maximum length
module: 2385mm
- maximum width
module: 1310mm
- angle of inclination: 30°

**K501 is a vertical design
one module.**

**Perfect solution for small areas,
and at the same time an opportunity
positioning of large modules in size
up to 1310 x 2385 mm.**

**The design allows for the installation of mono modules
as well as bifacial.**



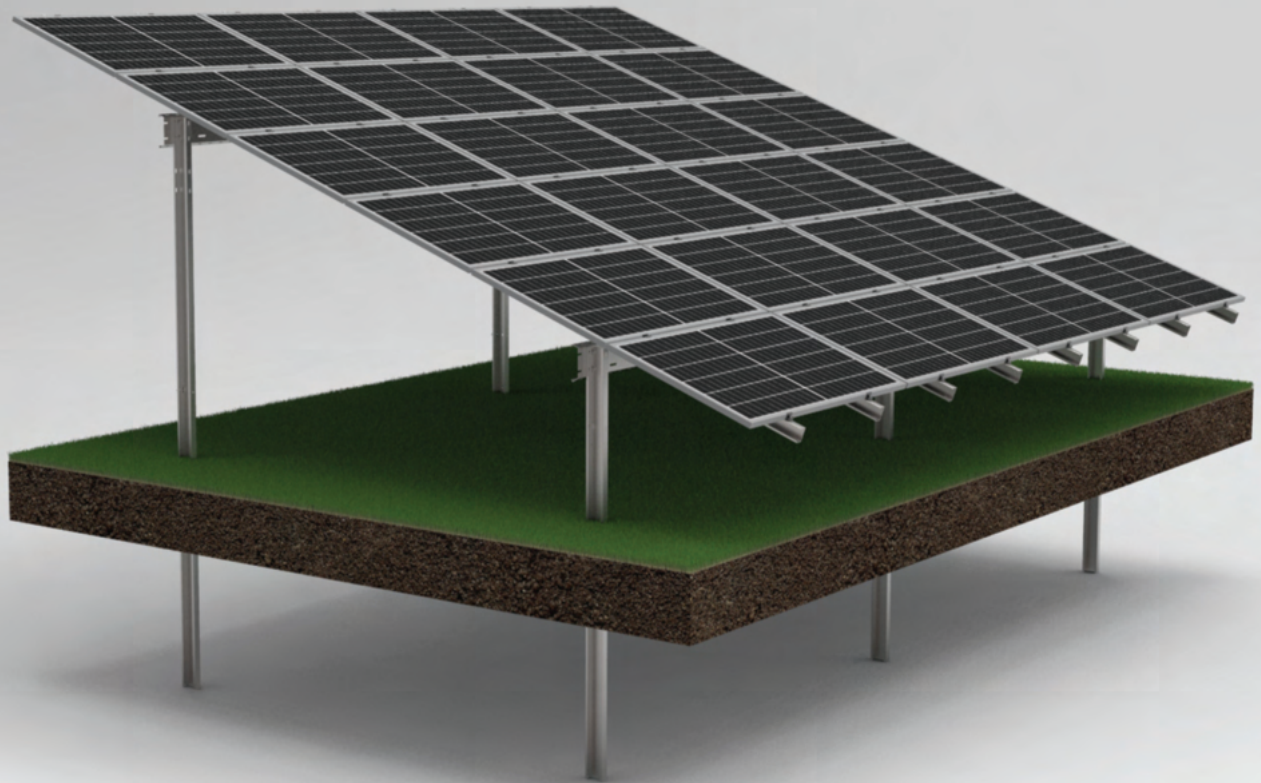

K504

- maximum width module: 1152mm
- inclination angle: 15°, 20°, 30°

K505

- maximum width module: 1152mm
- angle of inclination: 20°

K506

- maximum width module: 1062mm
- angle of inclination: 20°

K504/5/6 - systems characterized by horizontal system of 4, 5 or 6 modules.

Designed structures with large-scale businesses in mind solar power plants.

All-steel construction allows you to obtain any the length of the table, and an additional one

the advantage is modularity load-bearing elements due to which we can expand the existing one already installing additional panels photovoltaic.



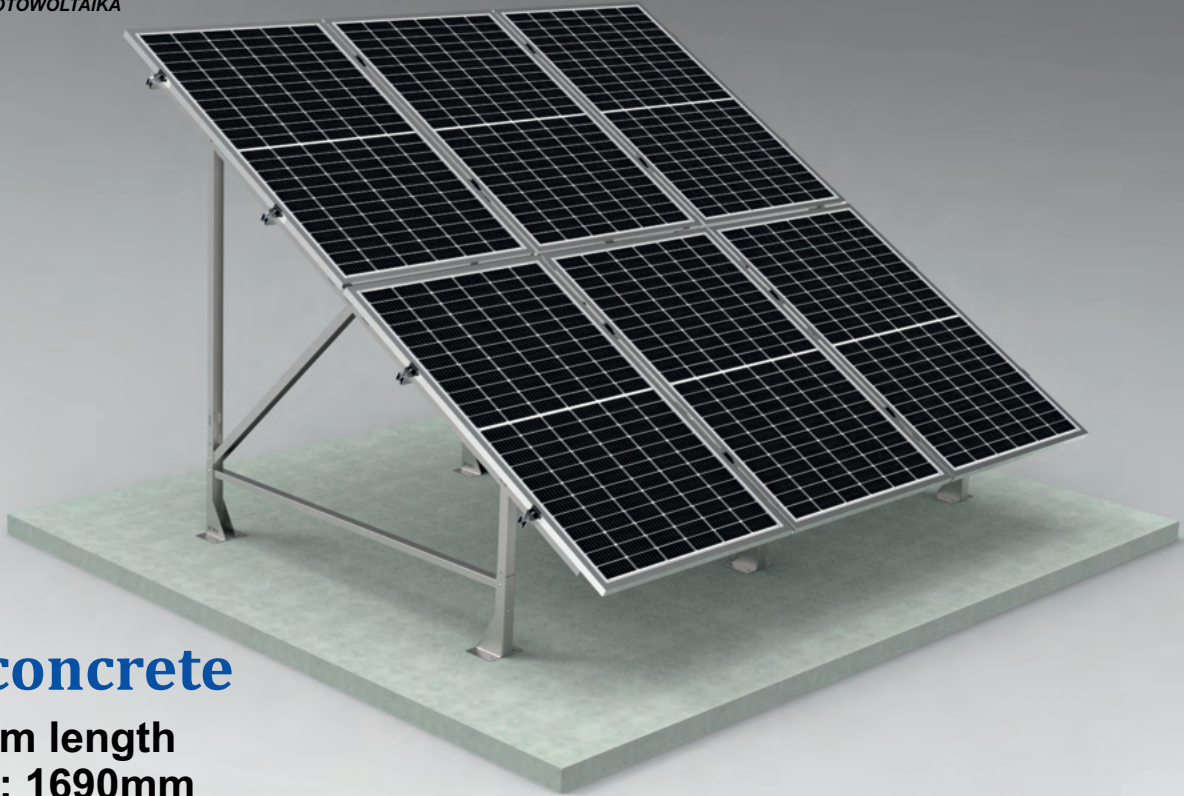

K502 concrete

- maximum length module: 1690mm
- angle of inclination: 30°
- maximum number of modules: 20

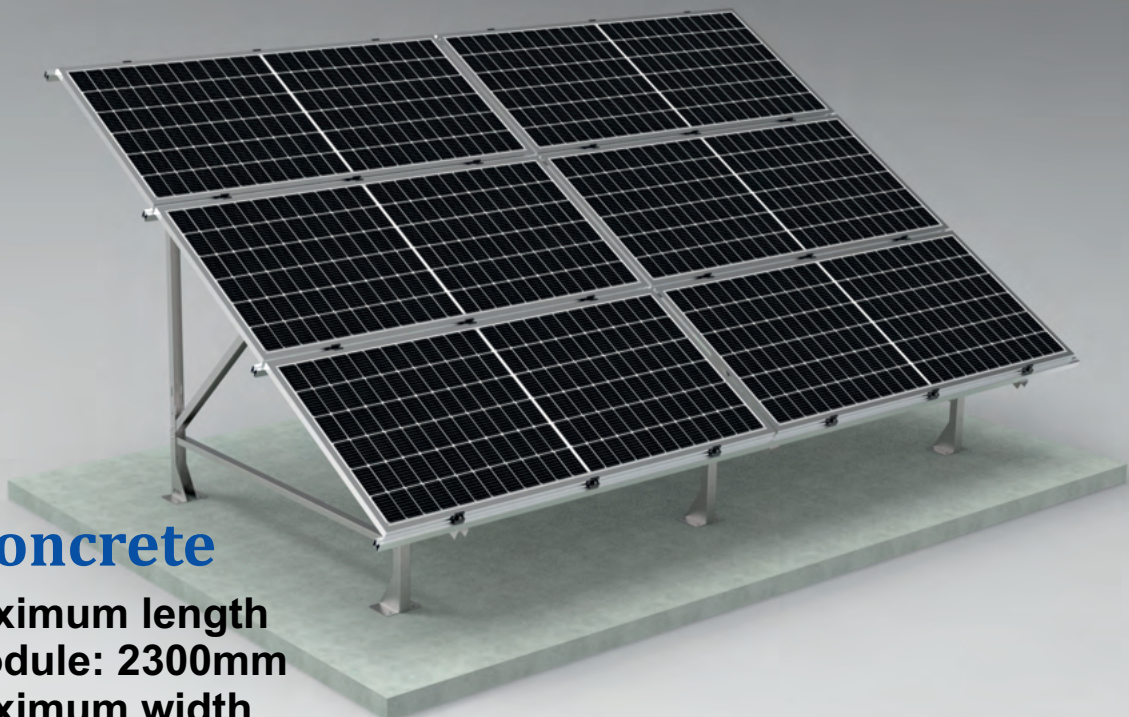

K503 concrete

- maximum length module: 2300mm
- maximum width module: 1052mm
- angle of inclination: 30°
- maximum number of modules: 18

K502/503 concrete - free-standing structures for 2 modules vertically or 3 horizontally with the option of attaching to concrete substrate. The perfect solution for installation, where it is impossible to standardly hammer in the steel structure due to cable routes and gas pipes running underground or sewage. Systems ready for installation in footings, screeds and concrete slabs.

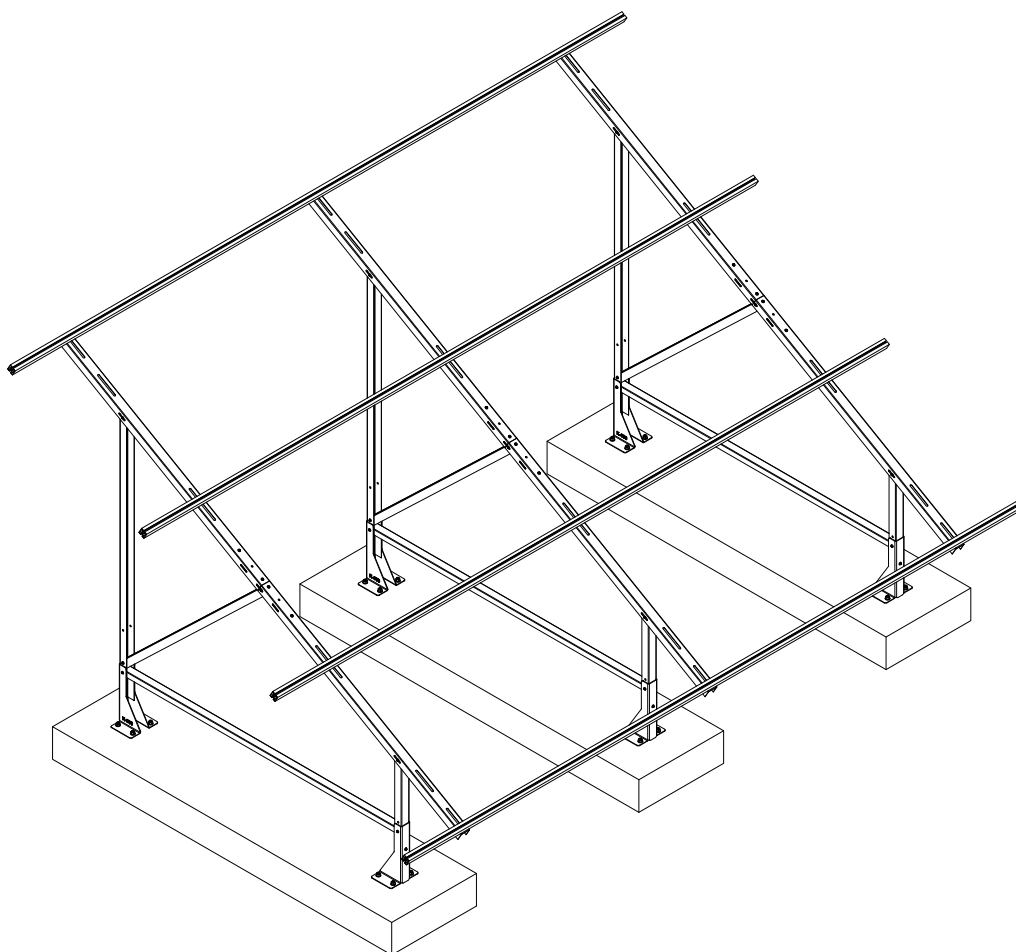

Concrete foot

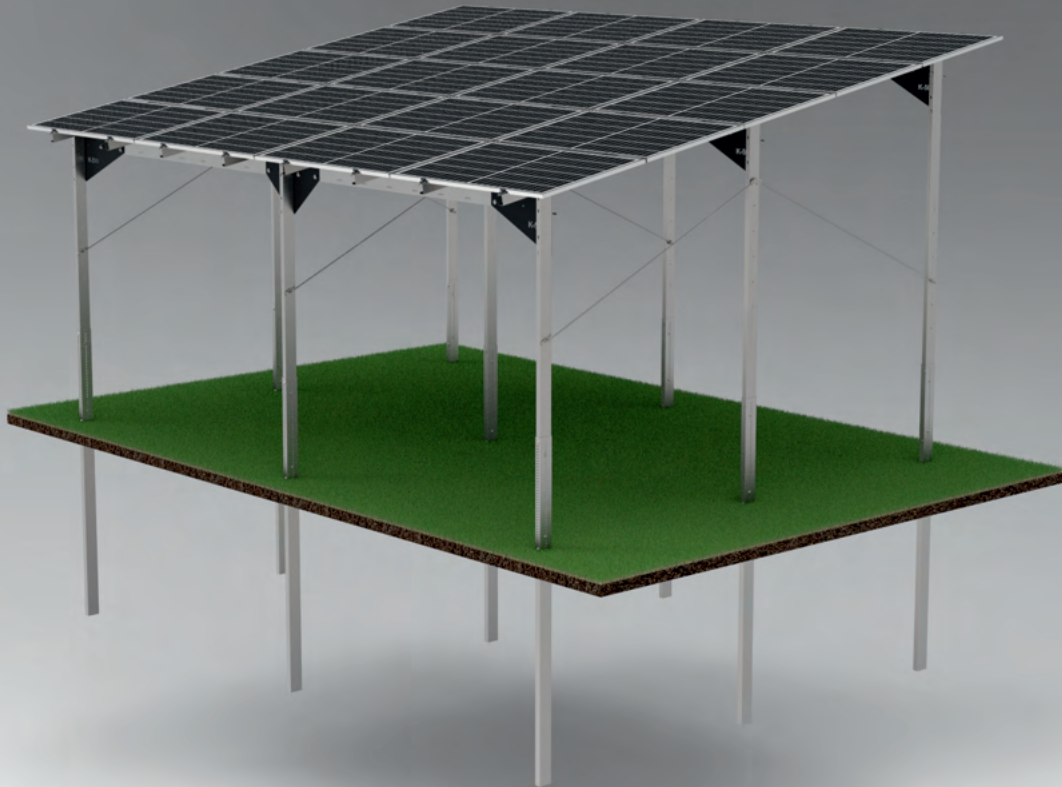

CARPORT STANDARD

LAYOUT 4 modules horizontally

- maximum width
module: 1152mm
- angle of inclination: 10°

LAYOUT 5 modules horizontally

- maximum width
module: 1152mm
- angle of inclination: 10°

LAYOUT 6 modules horizontally

- maximum width
module: 1062mm
- angle of inclination: 10°

**Carport standard - elevated photovoltaic structure
giving the user a double benefit:**

- electricity from the sun**
- vehicle protection against weather conditions**

Functionality, durability, strength and simplicity of installation

**these are just some of the advantages of our Carport. Construction height
reaching up to 3.39 m (at its lowest point) and spacing
supports equal to 5.25 m allow for free standing
large buses or agricultural machines.**

**A shelter designed for both industry and companies, for
use in home conditions as well as in
large-scale parking lots covered with cobblestones
paving or poured asphalt surfaces.**

**Carport installation is very simple and non-destructive
existing infrastructure. Another advantage is the possibility
expansion of the structure with any number of modules.**



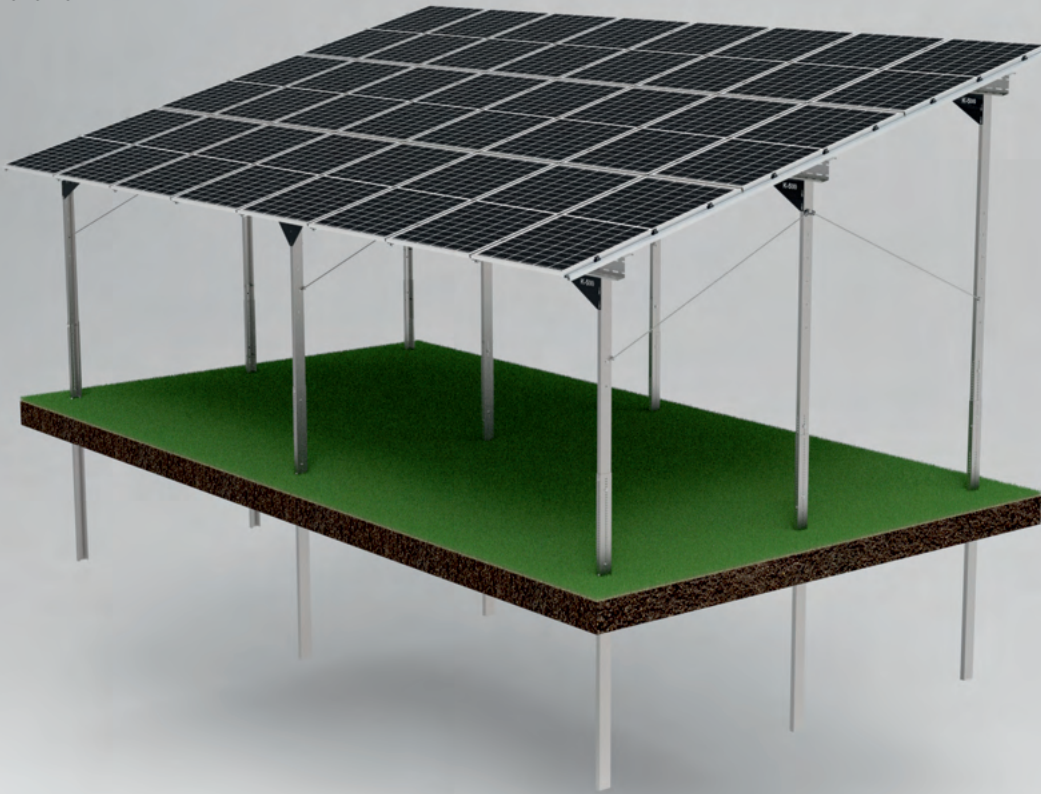

TIGHT CARPORT

- LAYOUT 2 modules vertically**
- maximum module length: 2390mm
 - angle of inclination: 10°, 15°
 - substructure equipped with an aluminum system drainage - 100% tight

- LAYOUT 3 modules vertically**
- maximum module length: 2320mm
 - angle of inclination: 10°, 15°
 - substructure equipped with an aluminum system drainage - 100% tight

Tight carport - another of the K500 products intended for parking vehicles/machines. Acceptable spacing and strength parameters are the same as in Carport standard. Undoubtedly, the greatest advantage of this design it is 100% tight. Thanks to the use of proprietary aluminum drainage system, user does not have to worry about water leaks between the panels. Vertical panel arrangement and modular structure this allows us to choose a structure for any type of construction number and type of panels.

Aluminum drainage system

Aluminum gutter

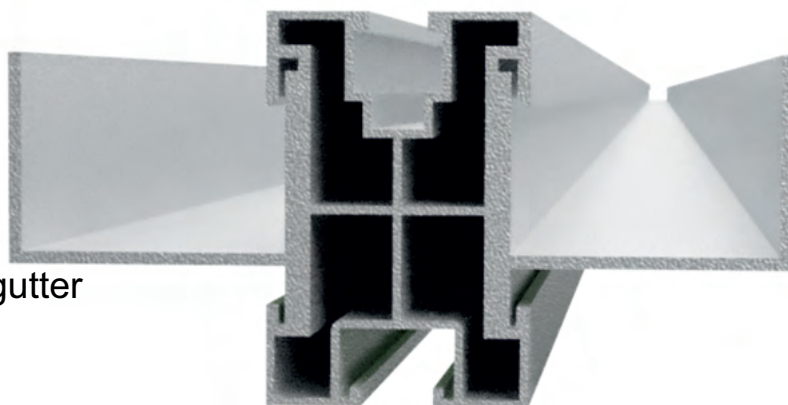

Mounting rail





CARPORT X1

LAYOUT 3 modules vertically

- maximum module length: 2320mm
- angle of inclination: 10°
- easy installation on concrete
- substructure equipped with an aluminum system drainage - 100% tight

The universal Carport X1 is innovative a global solution. System panel mounting allows for most sizes applicable modules available on the market, technology in the form of bifacial, monofacial and full screen. Application proprietary sealed aluminum K500 gutter system makes that the construction is tight and easy in assembly and operation. The Carport X1 shelter has the option expansion and extension of places parking lots adapted to customer needs that we fulfill individually. The entire structure is covered with an anode available in two versions color variants (silver and black). Possibility for an additional fee selecting a different color. The product is 100% made in Poland



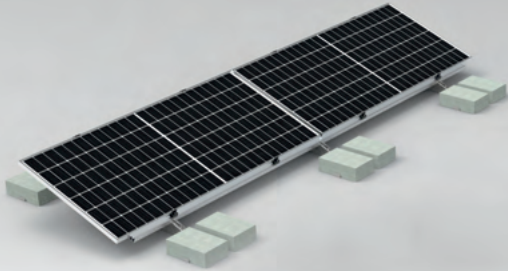

K8000

- many options for setting modules (horizontal, vertical, east-west, 2 horizontal, etc.)
- angle of inclination: from 10° to 20°
- ballast load or invasive installation

K8000 is a roof system dedicated to flat roofs.

Two ways of installation:

- invasive by attaching to the roof structure**
- structure loaded with concrete blocks.**

Appropriate setting of the angle of inclination of the modules (range from 10 to 20 degrees) guarantees less consumption materials and effective operation of the photovoltaic installation.

So that the product is optimized to suit your needs customers and met increasingly stringent market requirements trends, the K500 design department has developed the K8000 system that gives a lot

module arrangement combinations:

- inclined to the south in a horizontal position,**
 - inclined to the south in a horizontal position,**
 - east-west combination for vertical and horizontal positioning,**
 - horizontal arrangement of two modules one above the other,**
- There are many possibilities, it all depends on the specific one location and technical conditions on the roof.**



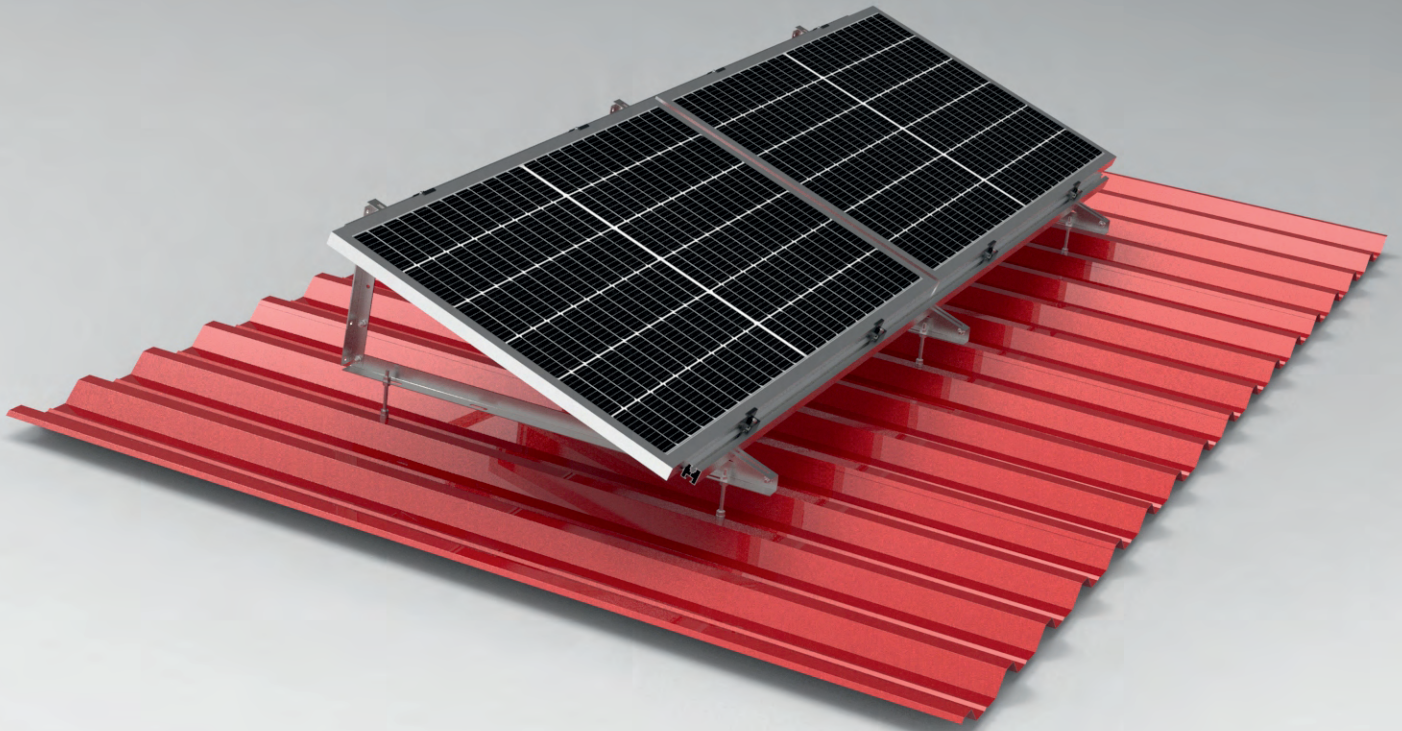

K9000

- horizontal arrangement of modules
- angle of inclination: from 15° to 30°
- maximum module width: 1152mm
- ballast load or invasive installation

K9000 - "set square" as an alternative to the structure roofs with horizontal module arrangement.

The most important advantages of the structure:

- simple assembly,
- small number of elements,
- adjustable angle of inclination from 15 to 30 degrees
- invasive installation or by adding weight concrete blocks.

Perfect design for small backyards photovoltaic installations on a flat roof.



NOTES

A large grid of graph paper for taking notes, consisting of 20 columns and 40 rows of small squares.

NOTES

A large grid area for taking notes, consisting of a 30x30 grid of small squares. The grid is empty and occupies most of the page below the 'NOTES' header.



Do you have any questions?
Contact us :)

K500 office

Telephone +48 67 307 00 36
E-mail biuro@k500.pl

Górzna 113
77-400 Złotów



www.k500.pl

<https://www.facebook.com/p/K500-100064026045222/>

